



Buzzer

Cat XLP917WEWE & XLP918WEWE

Instruction Manual

1 Specifications

Cat No.	XLP917WEWE	XLP918WEWE
Supply voltage	230 - 240 V a.c.	12 - 48 d.c.
Loudness (at one metre)	>65 dB	80 dB
Current consumption	25 mA	5 mA @ 12 V 9 mA @ 24 V 17 mA @ 48 V
Terminal capacity	2 x 1.5 mm ²	
IP Rating	IP41	
Storage temperature	-10° C to +55° C	
Operating temperature	-10° C to +55° C	
Resistant to the following agents	Hexane, methylated spirits, soapy water, diluted ammonia, diluted pure bleach (10%), glass cleaning substance, pre-impregnated wipes	
Not resistant to the following agents	Acetone, tar remover, trichloroethylene	

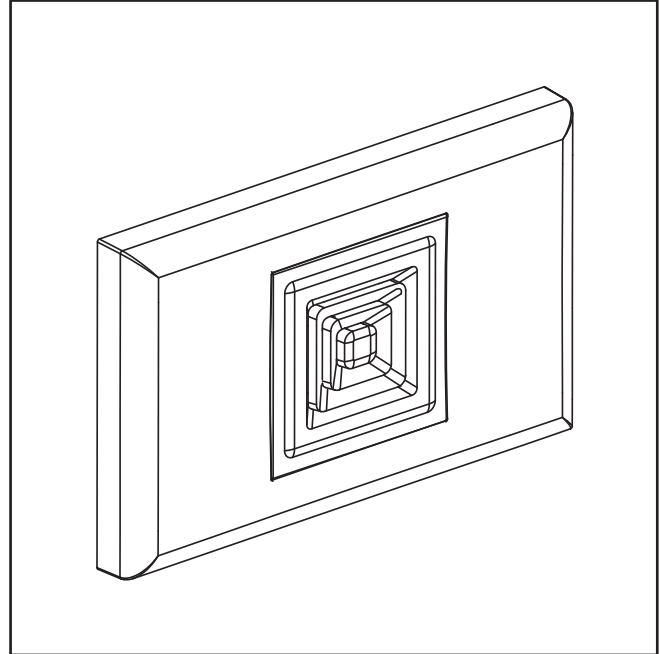

2 Operation

XLP917WEWE and XLP918WEWE emit a buzzing noise when the appropriate voltage is applied to the terminals. See specifications for the voltage of each model.

3 Mechanism Dimensions

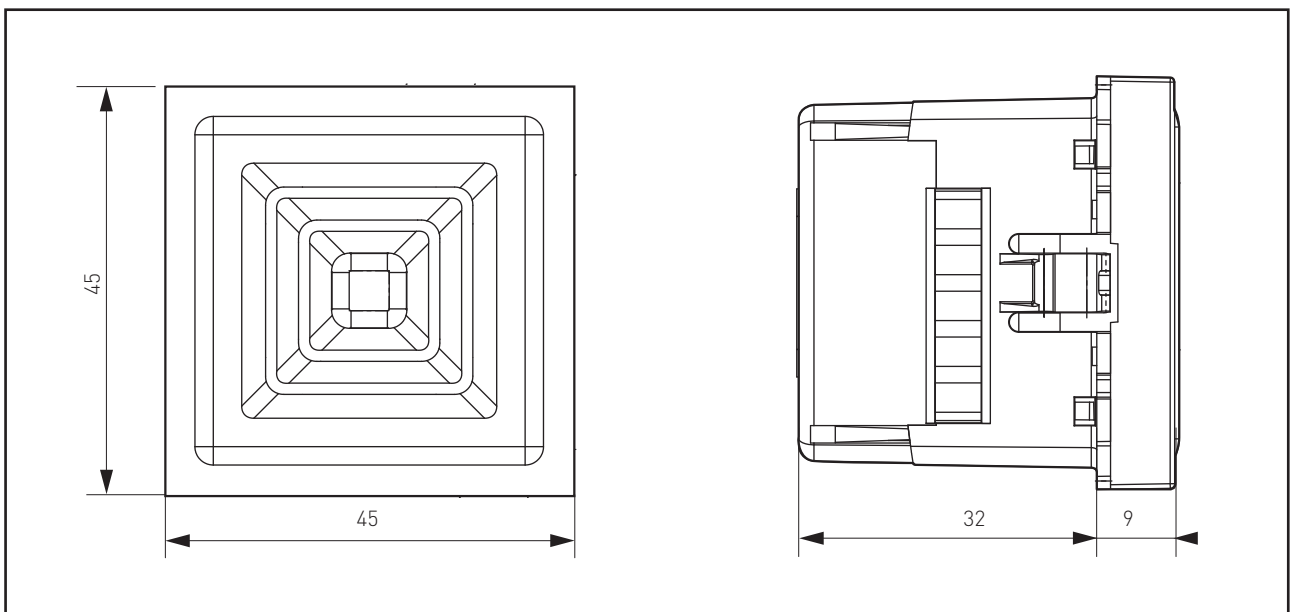

4 Wiring

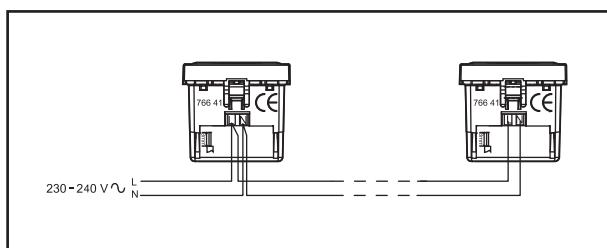

CAT XLP917WEWE wiring

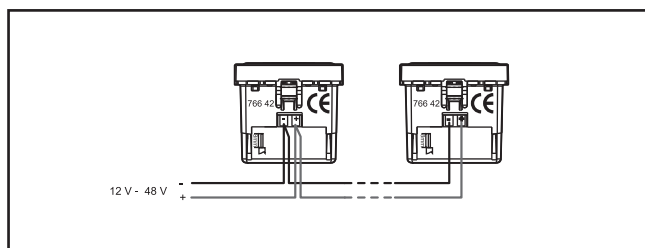

CAT XLP918WEWE wiring

5 Warning

XLP917WEWE must only be connected to the mains supply by a qualified electrician.

Warranty

HPM Cat XLP917WEWE and XLP918WEWE are warranted as here and after appears, against faulty material and/or workmanship for a period of one year from the day of purchase. The obligation of the manufacturer under this warranty is limited to servicing and replacing defective parts when the unit is returned to the authorised place of purchase. To obtain warranty repair, the purchase receipt should be returned with the product. This warranty becomes void on any unit which has been tampered with or damaged by accident, short circuited, loaded beyond rating or damaged otherwise by improper operation. The warranty is also conditional on the unit being installed by a licensed electrical contractor. All other warranties, whether expressed or implied, and whether arising by operation of law or otherwise are hereby excluded.

Customer Service

For all customer service and technical support please call Monday to Friday during business hours.

HPM Legrand Australia
1300 369 777
www.hpm.com.au

HPM Legrand - New Zealand
0800 476 009
www.hpm.co.nz

Legrand Australia Pty Ltd
ABN: 31 000 102 661

A Group Brand |  **legrand**[®]